

Outlet	Mark	Drive No.	To
0			
1	IWS		
2	2WS	12	11
3	NU		12
4	NU		13
5	NU		14
6	NU		15
7	NU		16
8	NU		17
9	9WS	14	18
10	NU		19
11			10
12			
13			21
14			22
15	NU		23
16	NU		24
17	NU		25
18	NU		26
19	NU		27
20	NU		28
21	NU		29
22	NU		30
23	NU		31
24			90

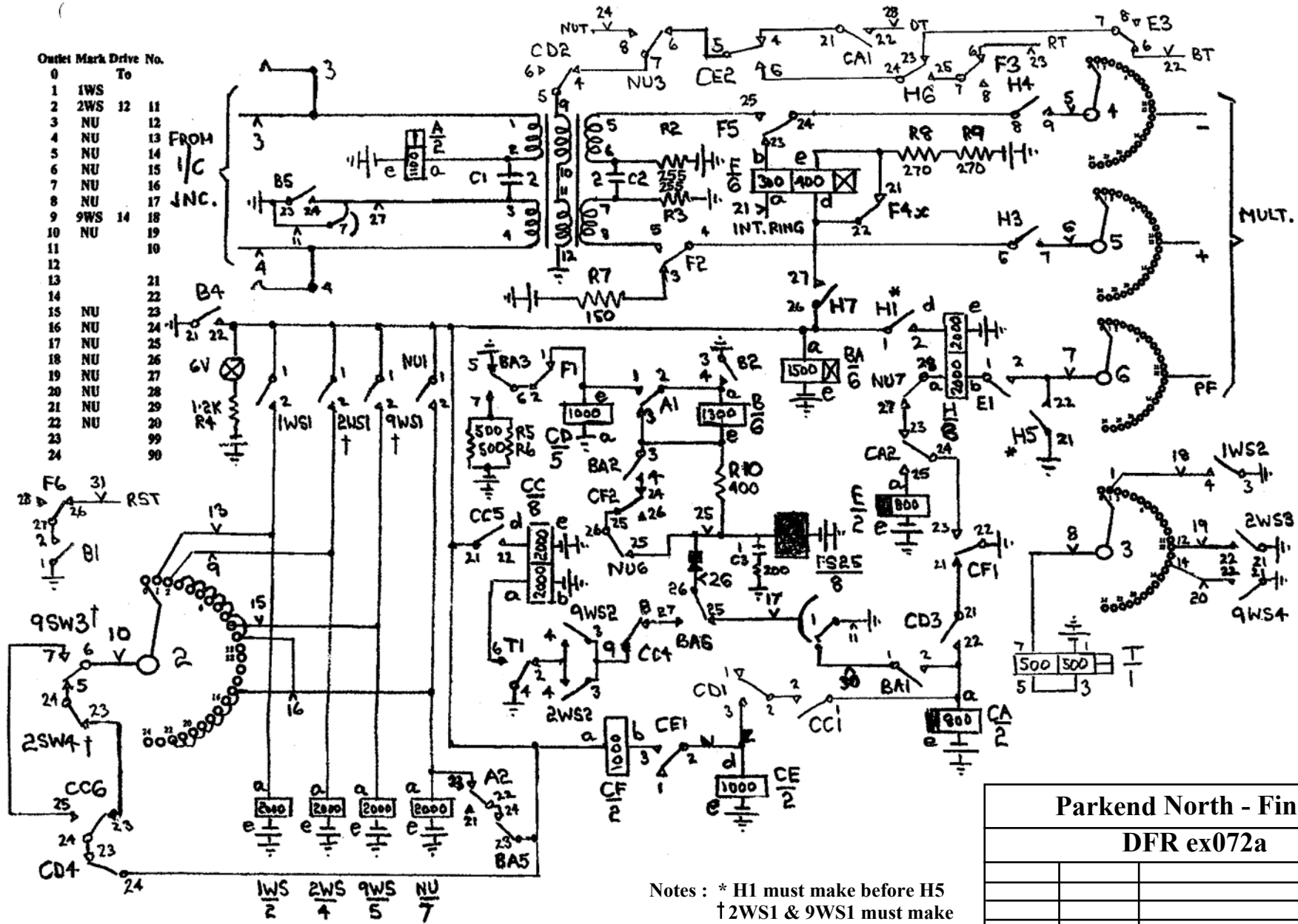

- Unused Contacts
- B3 (5,6,7)
 - B6 (25,26)
 - BA4 (21,22)
 - CA1 (21,22)
 - CC2 (3,4,5)
 - CC3 (6,7)
 - CC7 (26,27)
 - CC8 (28,29)
 - CD5 (25,26,27)
 - E2 (3,4,5)
 - H2 (3,4,5)
 - H8 (28,29)
 - NU2 (3,4,5)
 - NU4 (21,22)
 - NU5 (23,24)
 - 9WS5 (23,24,25)

Notes : * H1 must make before H5
 † 2WS1 & 9WS1 must make before 2WS4 & 9WS3 break

Parkend North - Final Selector		
DFR ex072a		
ISSUE A	28/07/2015	Opening Issue
<div style="display: flex; justify-content: space-between; align-items: center;"> Dean Forest Railway </div>		